

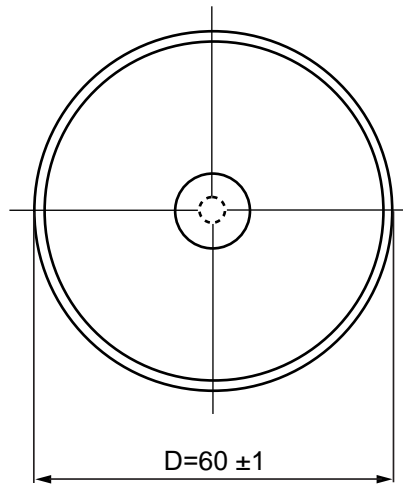

100kV 1000PF

Unit: mm

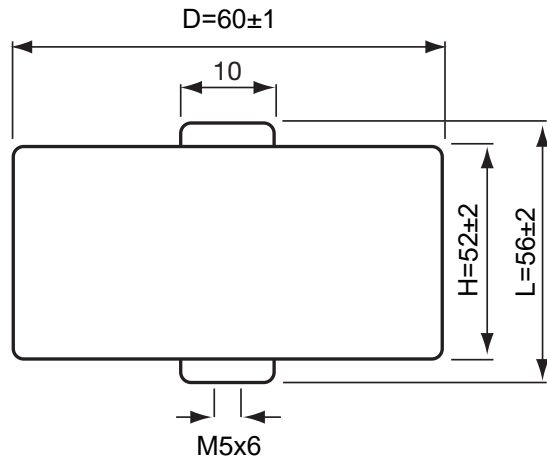

- 1, Rated voltage: 100kVdc
- 2, Rated capacitance: 1000PF \pm 10% (1kHz, 1Vrms)
- 3, AC withstand voltage: 80kVac 60 Sec
- 4, Dissipation factor: Max 0.2%
- 5, Temperature characteristics: +22/-33%
- 6, Dielectric: N4700
- 7, Insulation resistance: Min 100G Ω
- 8, AC corona voltage: \leq 10pC @ 20kV
- 9, Operating temperature range: -30 $^{\circ}$ C ~ +85 $^{\circ}$ C
- 10, Storage temperature range: -35 $^{\circ}$ C ~ +85 $^{\circ}$ C
- 11, Terminal torque: 1.5Nm max
- 12, Relative air humidity: 75% max
- 13, P/N: AXCT8GE40102KAD1B

Cixi AnXon Electronic Co., Ltd

CT8G series, High Voltage Ceramic Capacitor

Spec: 100kV 1000pF

Customer:

Drawing No.:

Contract No.: