

WL10

LIQUID LEAK SENSORS

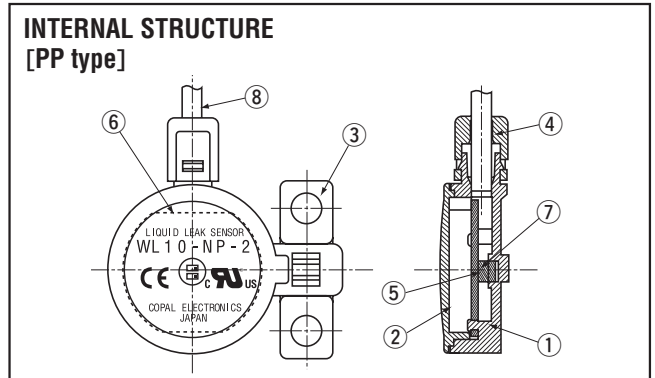
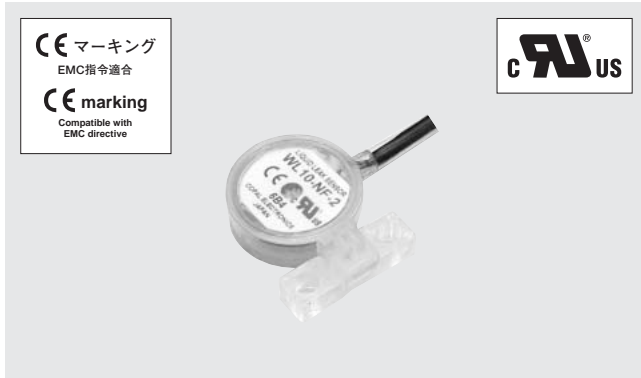

Part name	Material
① Housing	PP
② Cover	
③ Mounting plate	
④ Sealing cap	Glass-Epoxy
⑤ P.C. board	
⑥ Label	Polyester film
⑦ Photo-interrupter	—
⑧ Cable	PVC

FEATURES

- Low effects at detection point by introduction of new optical technology (Patent Pending)
- Needless shade plate, High precision
- Compact and Slim size (ϕ 25 mm, t = 10 mm)
- Lead-free Soldering

MODEL NUMBER DESIGNATION

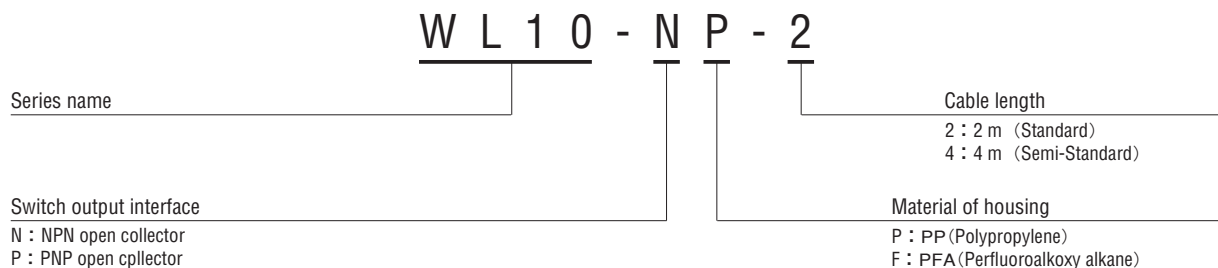

LIST OF MODEL NUMBERS

Switch output interface		Model number			
		NPN		PNP	
Material of housing		PP	PFA	PP	PFA
Cable length	2 m	WL10-NP-2	WL10-NF-2	WL10-PP-2	WL10-PF-2
	4 m	↻ WL10-NP-4	↻ WL10-NF-4	↻ WL10-PP-4	↻ WL10-PF-4

※Verify the above model numbers when placing orders.

The products marked ↻ are manufactured upon receipt of order basis.

STANDARD SPECIFICATIONS

● Unless otherwise specified, the specs are defined at an ambient temperature of 25 ± 5 °C and excitation voltage of 24 V DC.

Item	Model number	WL10	
		NPN	PNP
General specifications	Operating temp. range	°C - 10 ~ 60	
	Operating humidity	%RH 35 ~ 85 (No condensation)	
	Storage temp.	°C - 20 ~ 70 (Atmospheric pressure, humidity 65 %RH maximum)	
	Pressure medium	Water (PP) / Corrosive fluids compatible with PFA	
	Material of housing	PP/PFA	
	Net weight	g	Approx. 30 (WL10-*P-2)
Power	Supply voltage	V DC 12 ~ 24 \pm 10 %	
	Consumption current	mA maximum 10 (Except open collector output)	
Output	Switching capacity	Voltage endurance : 30 VDC Sink current : 50 mA maximum (Over current protection)	Voltage endurance : 24 VDC Sourced current : 50 mA maximum (Over current protection)
	Residual voltage	V maximum 1.0 V maximum	2.0 V maximum
	Operation grade	Normal condition : Switch output is ON / Green LED is ON Leakage detection : Switch output is OFF / Red LED is ON	

ENVIRONMENTAL CHARACTERISTICS

Test item	Test conditions	Specification
Vibration	10 ~ 500 Hz, 1.5 mm maximum / 98.1 m / S ² , 3 directions for 2 hours each	Meets standard specifications
Shock	490 m/s ² , 3 directions for 3 times each	
Protection grade	IP-67	
EMC	EMI : EN55011: 2007, A2 : 2007 Group 1, class B EMS : EN61326-1: 2006 Table 2	

INTERNAL ELECTRICAL SCHEMATICS

● NPN

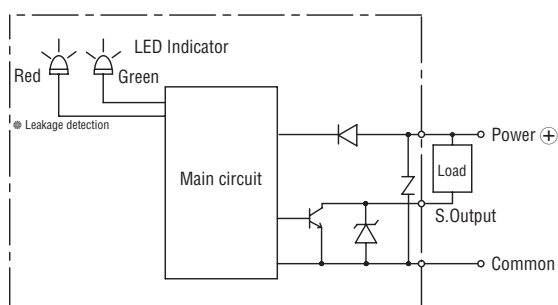

● PNP

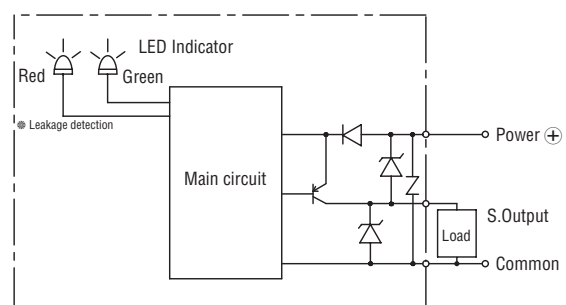

WL10 LIQUID LEAK SENSORS

OUTLINE DIMENSION

Unless otherwise specified, tolerance: ± 0.5 (Unit: mm)

● Material of housing - PP

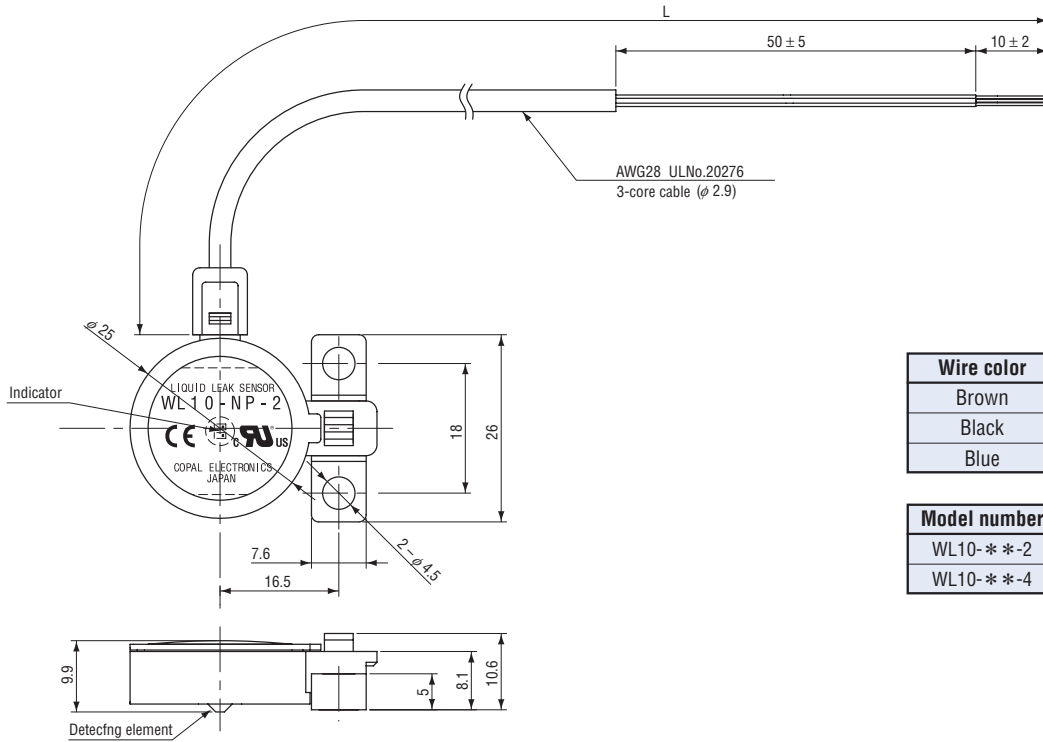

Wire color	Connection
Brown	Power ⊕
Black	Output
Blue	Common

Model number	Cable length
WL10-**-2	2000 \pm 100 mm
WL10-**-4	4000 \pm 200 mm

● Material of housing - PFA

