

7/8" (22.2 mm) Conductive Plastic Potentiometer, Bushing Mount Type

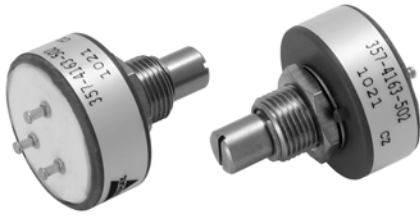

FEATURES

- 7/8" diameter single turn
- Compact size, advanced design technology
- Offer a cost effective solution to your potentiometer requirements
- Suitable model for all industrial applications
- Compliant to RoHS Directive 2002/95/EC



| ELECTRICAL SPECIFICATIONS | | |
|---------------------------------|---|-----------------------------|
| PARAMETER | | |
| Resistance | Standard range, 1 kΩ to 50 kΩ | |
| Tolerance | STANDARD ± 20 % | SPECIAL TO ± 10 % |
| Linearity (Independent) | STANDARD ± 2.0 % | SPECIAL ± 1.0 % |
| Output Smoothness | 0.1 % maximum | |
| TCR | ± 600 ppm/°C maximum | |
| Power Rating | 1.0 W at 70 °C derated to 0 W at 125 °C | |
| Electrical Travel | 340° ± 3° | |
| End Voltage | 0.5 % maximum | |
| Dielectric Withstanding Voltage | 1000 V _{RMS} , 60 Hz | |
| Insulation Resistance | 1000 MΩ, 500 V _{DC} | |

| MECHANICAL SPECIFICATIONS | | |
|---------------------------|---|--|
| PARAMETER | | |
| Rotation | 360° continuous (optional mechanical stops 340° ± 3°) | |
| Mounting | 3/8 - 32 UNEF - 2A | |
| Operating Torque Maximum | Starting and running 3.68 mNm (0.5 oz. - in) | |
| Shaft Tolerance Maximum | | |
| Runout | 0.13 mm (0.005") | |
| End Play | 0.25 mm (0.010") | |
| Radial Play | 0.13 mm (0.005") | |
| Weight | 17.5 g (0.62 oz.) | |

| ORDERING INFORMATION/DESCRIPTION | | | | | | | | |
|----------------------------------|---------|---|-----------------|--------------------------|----------------------|------------------|---|--------|
| 357 | B | 0 | 10K | 20 % | A | BO50 | 0 P 22 | e4 |
| MODEL | STYLE | FEATURES | OHMIC VALUE | TOLERANCE ON OHMIC VALUE | LINEARITY | PACKAGING | SHAFT TYPE | LEAD |
| | Bushing | 0 Non turn pin and continuous rotation | | | | Box of 50 pieces | Shaft diameter 0 = 6.0 mm or 1 = 6.35 mm (1/4") | Finish |
| | | 1 No non turn pin and continuous rotation | From 1K to 50 K | ± 10 % or ± 20 % | X: ± 2 % A: ± 1 % | | Shaft type P = Plain S = Slotted FMF (from Mounting face) | |
| | | 2 Non turn pin, with stops on rotation | | | | | Range from 12 mm to 75 mm in 1 mm increments | |
| | | 3 No non turn pin with stops on rotation | | | | | | |

| SAP PART NUMBERING GUIDELINES | | | | | | |
|-------------------------------|----------|-------------|--------------------------|-----------|------------------|------------|
| 357B | 2 | 203 | M | X | B25 | 1S22 |
| MODEL | FEATURES | OHMIC VALUE | TOLERANCE ON OHMIC VALUE | LINEARITY | PACKAGING | SHAFT TYPE |
| | | 203 = 20K | M: ± 20 %/K: ± 10 % | X: ± 2 % | Box of 50 pieces | |

Model 357

Vishay Spectrol

7/8" (22.2 mm) Conductive Plastic Potentiometer, Bushing Mount Type



DIMENSIONS in millimeters

Ø 6.35 mm SHAFT VERSION

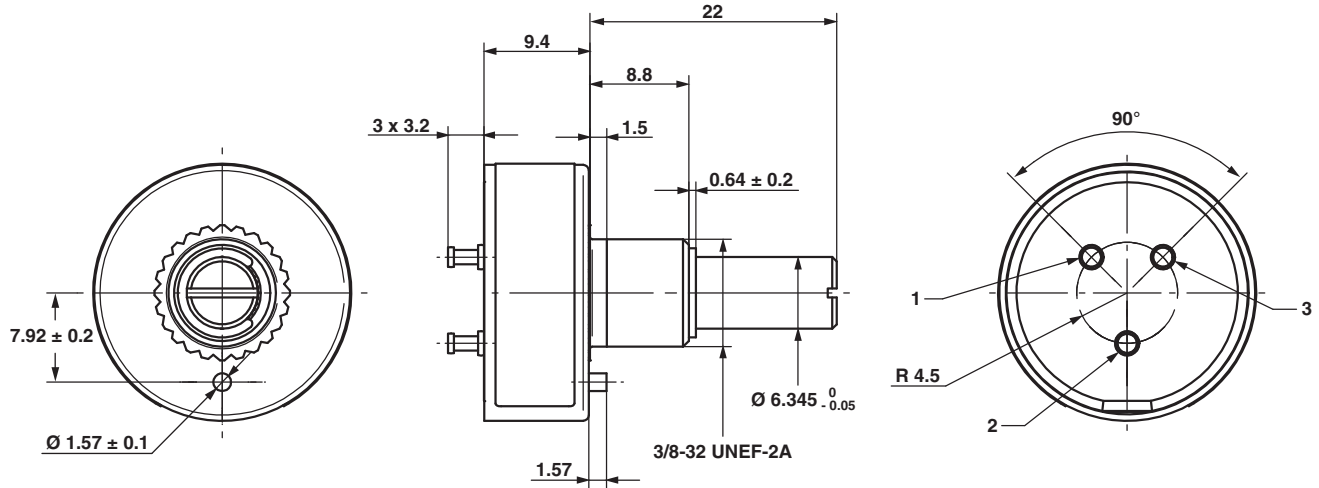

Ø 6.0 mm SHAFT VARIATION: METRIC

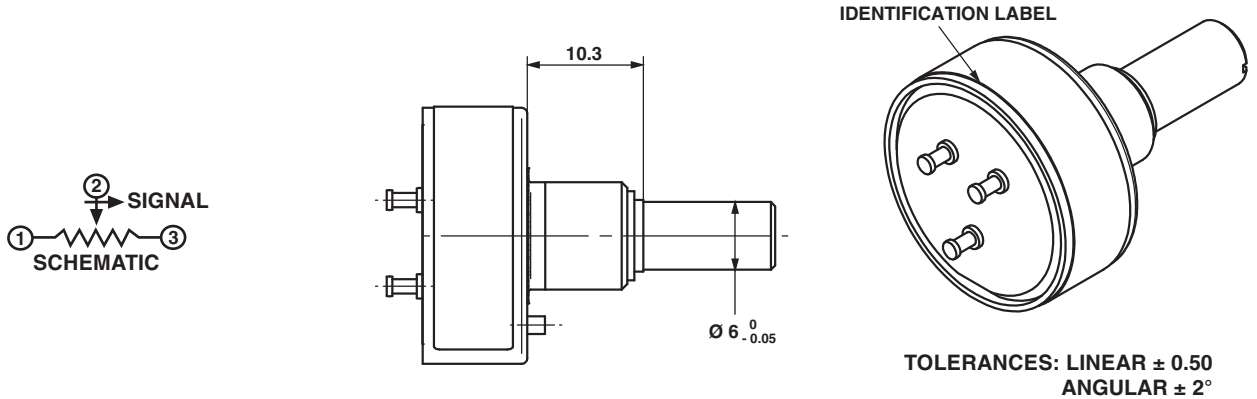

| ENVIRONMENTAL SPECIFICATIONS | |
|------------------------------|-----------------------------|
| Vibration | 15 g, 10 Hz to 2000 Hz |
| Shock | 50 g |
| Load Life | 1000 h |
| Storage Temperature Range | - 55 °C to + 125 °C |
| Life | 5 000 000 shaft revolutions |
| Materials | |
| Housing | Thermoplastic housing |
| Bushing | Brass, nickel plated |
| Rear Lid | Alumina |
| Shaft | Stainless steel |
| Terminals | Turret type, solder plated |
| Bushing Mount Hardware | |
| Lockwasher Internal Tooth | Steel, nickel plated |
| Panel Nut | Brass nickel plated |

| MARKING | |
|---------------------|---|
| Unit Identification | Manufacturer's name and model number, resistance value and tolerance, linearity specification date code and terminal identification |

| RESISTANCE VALUE | |
|------------------|---------------------------|
| Ohms | 1K, 2K, 5K, 10K, 20K, 50K |



Disclaimer

ALL PRODUCT, PRODUCT SPECIFICATIONS AND DATA ARE SUBJECT TO CHANGE WITHOUT NOTICE TO IMPROVE RELIABILITY, FUNCTION OR DESIGN OR OTHERWISE.

Vishay Intertechnology, Inc., its affiliates, agents, and employees, and all persons acting on its or their behalf (collectively, "Vishay"), disclaim any and all liability for any errors, inaccuracies or incompleteness contained in any datasheet or in any other disclosure relating to any product.

Vishay makes no warranty, representation or guarantee regarding the suitability of the products for any particular purpose or the continuing production of any product. To the maximum extent permitted by applicable law, Vishay disclaims (i) any and all liability arising out of the application or use of any product, (ii) any and all liability, including without limitation special, consequential or incidental damages, and (iii) any and all implied warranties, including warranties of fitness for particular purpose, non-infringement and merchantability.

Statements regarding the suitability of products for certain types of applications are based on Vishay's knowledge of typical requirements that are often placed on Vishay products in generic applications. Such statements are not binding statements about the suitability of products for a particular application. It is the customer's responsibility to validate that a particular product with the properties described in the product specification is suitable for use in a particular application. Parameters provided in datasheets and/or specifications may vary in different applications and performance may vary over time. All operating parameters, including typical parameters, must be validated for each customer application by the customer's technical experts. Product specifications do not expand or otherwise modify Vishay's terms and conditions of purchase, including but not limited to the warranty expressed therein.

Except as expressly indicated in writing, Vishay products are not designed for use in medical, life-saving, or life-sustaining applications or for any other application in which the failure of the Vishay product could result in personal injury or death. Customers using or selling Vishay products not expressly indicated for use in such applications do so at their own risk and agree to fully indemnify and hold Vishay and its distributors harmless from and against any and all claims, liabilities, expenses and damages arising or resulting in connection with such use or sale, including attorneys fees, even if such claim alleges that Vishay or its distributor was negligent regarding the design or manufacture of the part. Please contact authorized Vishay personnel to obtain written terms and conditions regarding products designed for such applications.

No license, express or implied, by estoppel or otherwise, to any intellectual property rights is granted by this document or by any conduct of Vishay. Product names and markings noted herein may be trademarks of their respective owners.